

SMD Chip Tantalum Capacitor

How To Order:

Series: TC Part No.

<u>TC</u>	<u>A</u>	<u>106</u>	<u>K</u>	<u>S</u>
Series Chip Tantalum Capacitor	Case A B C D E	Capacitance 10PF=100 100PF=101 1000PF=102 1NF=1000PF=10 2 1UF=1000000PF =105	Tolerance K=10% M=20%	Voltage 160=16V 500=50V 101=100V

Description: Tantalum 10uF 16V A case.

Note:

The normal packing of Tantalum Chip Cap. is Taped/Reel.

Quantity of A、 B case is 2000pcs/reel.

Quantity of C、 D case is 500pcs/reel.

Quantity of E case is 400pcs/reel.

SMD Chip Tantalum Capacitor

Tantalum Electrolytic Capacitors Surface Mount Type

Features

- General purpose surface mount type
- Compact size & wide CV range.
- High solderability & stable characteristics for soldering
- Compatible with all popular automatic pick and place equipment.

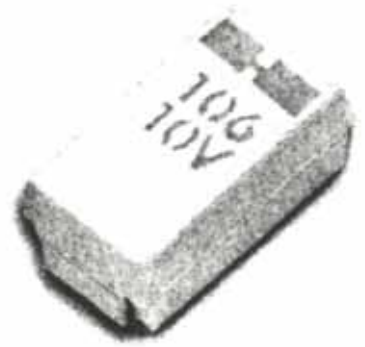

SPECIFICATION:

Item	Performance Characteristics																					
Operating Temperature Range	-55 to +125																					
Rated Working Voltage Range	4 to 50 V DC																					
Nominal Capacitance Range	0.1 to 220 μ F																					
Capacitance Tolerance	$\pm 20\% \pm 10\%$ (120Hz, +20)																					
Leakage Current	1 0.01CV or 0.5 [μ A] Whichever is greater measured after 2 minutes application of rated working voltage at +20																					
tan (120Hz, +20)	0.04 max. for 3.3 μ F																					
	0.06 max. for 4.7 to 68 μ F.																					
	0.08 max. for 100 to 220 μ F																					
Characteristics at High and Low Temperature	-55	Capacitance change $\pm 12\%$ of initial measured value at +20																				
	+125	Leakage current 12.5% of initial measured value																				
		Capacitance change $\pm 15\%$ of initial measured value at +20																				
Moisture Resistance	Test conditions Relative humidity : 90 to 95% without load Ambient temperature : +40 Duration : 500 hours Post test requirements at +20 Leakage current : Initial specified value Capacitance change : $\pm 10\%$ of initial measured value tan : Initial specified value																					
Endurance	<table border="1"> <thead> <tr> <th>Item</th> <th>Conditions</th> <th>Derating</th> <th>Rating</th> </tr> </thead> <tbody> <tr> <td>Duration</td> <td></td> <td>2000 hours</td> <td>2000 hours</td> </tr> <tr> <td>Ambient temperature</td> <td></td> <td>+125</td> <td>+85</td> </tr> <tr> <td>Applied voltage</td> <td></td> <td>Derated working voltage</td> <td>Rated working voltage</td> </tr> <tr> <td>Source impedance</td> <td></td> <td>1 Ω</td> <td>1 Ω</td> </tr> </tbody> </table>		Item	Conditions	Derating	Rating	Duration		2000 hours	2000 hours	Ambient temperature		+125	+85	Applied voltage		Derated working voltage	Rated working voltage	Source impedance		1 Ω	1 Ω
	Item	Conditions	Derating	Rating																		
	Duration		2000 hours	2000 hours																		
	Ambient temperature		+125	+85																		
	Applied voltage		Derated working voltage	Rated working voltage																		
	Source impedance		1 Ω	1 Ω																		
	Derating voltage + 125																					
	Working voltage [V] DC	4	6.3	10	16	20	25	35	50													
	Derating voltage[V] DC	2.5	4	6.3	10	13	16	22	32													
	Post test requirements at +20																					
Leakage current	: 125% of initial specified value																					
Capacitance change	: $\pm 10\%$ of initial measured value																					
tan	: Initial specified value																					
Shelf Life	Test conditions Duration : 2000 hours Ambient temperature : +125 Applied voltage : (none)		Post test requirements at +20 Same limits for "Endurance".																			
Solder Heat Resistance	The capacitor shall withstand dipping into solder bath for 5 ± 1 seconds at 260 ± 5																					

SMD Chip Tantalum Capacitor

Tantalum Capacitor CHIP TYPE OUTLINE DRAWINGS

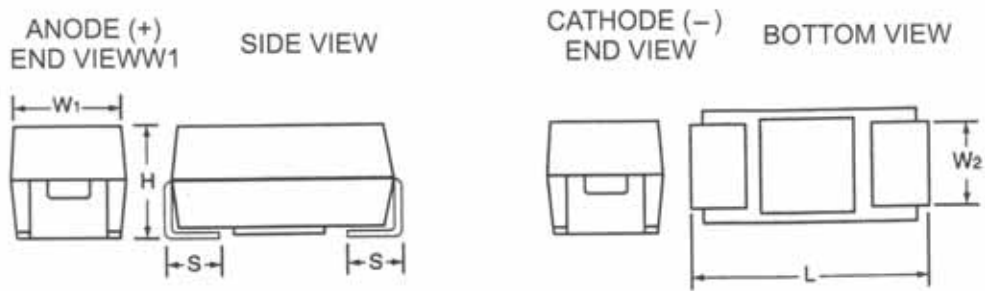

Dimensions Millimeters (Inch)

Case Size	$L \pm 0.2$ (0.008)	$W1 \pm 0.2$ (0.008)	$H \pm 0.2$ (0.008)	$S \pm 0.3$ (0.012)	$W 2 \pm 0.1$ (0.004)
A	3.2 (0.126)	1.6 (0.063)	1.6 (0.063)	0.8 (0.031)	1.2 (0.047)
B	3.5 (0.137)	2.8 (0.110)	1.9 (0.075)	0.8 (0.031)	2.2 (0.087)
C	6.0 (0.236)	3.2 (0.126)	2.5 (0.098)	1.3 (0.051)	2.2 (0.087)
D	7.3 (0.287)	4.3 (0.169)	2.8 (0.110)	1.3 (0.051)	2.4 (0.094)

Rated Voltage, Capacitance of Capacitors

Rated Voltage (V)	4	6.3	10	16	20	25	35	50
Capacitance (μF)	Case size							
0.10 (104)							A	A
0.15 (154)							A	B
0.22 (224)							A	B
0.33 (334)							A	B
0.47 (474)						A	AB	C
0.68 (684)					A	A	B	C
1.0 (105)				A	A	AB	B	C
1.5 (155)			A	A	AB	B	C	D
2.2 (225)		A	A	AB	B	C	C	D
3.3 (335)	A	A	AB	AB	B	C	C	D
4.7 (475)	A	AB	AB	B	C	CD	CD	D
6.8 (685)	A	AB	AB	BC	C	CD	D	
10 (106)	AB	AB	ABC	BC	CD	D	D	
15 (156)	B	BC	C	BC	D	D		
22 (226)	BC	C	C	CD	D			
33 (336)	BC	CD	CD	D	D			
47 (476)	C	CD	D	D				
68 (686)	CD	CD	D					
100 (107)	CD	CD	D					
150 (157)	D							
220 (227)	D							

SMD Chip Tantalum Capacitor

Dimensions of the carrier tape and standard parts quantity per reel.

Dimensions

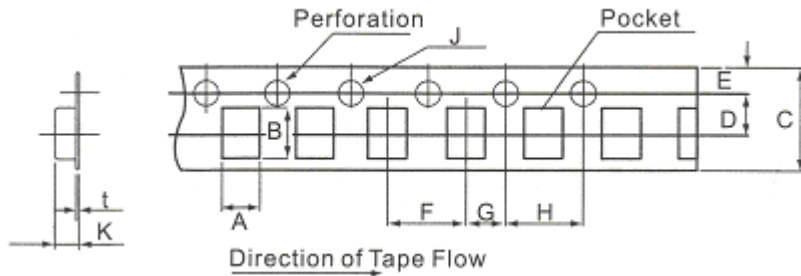

(Unit: mm)

Case Size	A ±0.1	B ±0.1	C ±0.3	D ±0.1	E ±0.1	F ±0.1	G ±0.1	H ±0.1	J ±0.1 -0	K MAX	t	Quantity Per Reel
A	1.9	3.5	8.0	3.5	1.75	4.0	2.0	4.0	1.5	2.5	0.2	2000
B	3.3	3.9	8.0	3.5	1.75	4.0	2.0	4.0	1.5	2.5	0.2	2000
C	3.7	6	12.0	5.5	1.75	8.0	2.0	4.0	1.5	3.0	0.3	500
D	4.8	7.7	12.0	5.5	1.75	8.0	2.0	4.0	1.5	3.4	0.3	500

Inserting Direction(Polarity Orientation)
Polarity L: To be insert with the positive side to the feed hole.

Polarity R: To be insert with the positive side to the feed hole



Reel Dimensions

(Unit: mm)

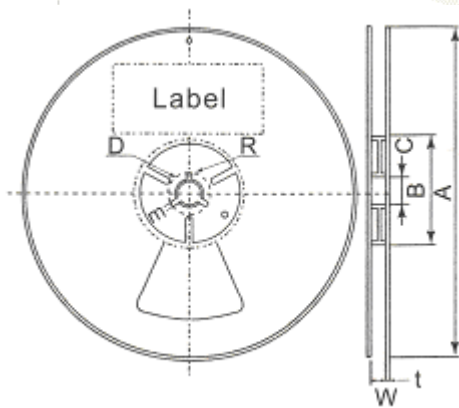

Tape Leader and Tailer

Tape width	8	12
A_{-3}^0	180	
B_0^{+1}	60	
$C_{\pm 0.2}$	13	
$D_{\pm 0.8}$	21	
$E_{\pm 0.5}$	2.0	
$W_{\pm 0.3}$	9.0	13.0
$t_{\pm 0.4}$	1.3	
$R_{\pm 0.4}$	10.5	

